

LED Explosion-proof Highbay Light



CONSTRUCTION:

Low-copper aluminum alloy with polycarbonate optical lens, a durable powder-coated finish, and silver color

OPTICAL SYSTEM:

LED 3030 chips. 120° beam angle.

WARRANTY:

5-year limited warranty. Actual performance may differ as a result of end-user environment and application.

ELECTRICAL:

Available as 100-277V input.

Operating Temperature:

100W: -40°C to +60°C (-40°F to +140°F)

150W: -40°C to +55°C (-40°F to +131°F)

240W: -40°C to +45°C (-40°F to +113°F)

CONTROL & DIMMING:

1-10V Dimming

FEATURES

- Class I, Division 2, Groups A, B, C, D
- T-Code: T5
- IP66 & IK08 double protection
- No UV or IR in the beam
- Flexible installation
- Easy installation and maintenance
- No ingress of dust; complete protection against contact
- Lifetime of LED @Ta=25°C(77°F):
 - 96,395hrs-L80
 - 153,225hrs-L70

SUITABLE APPLICATIONS

- Warehouses
- Factory
- Workshops
- Petroleum and petrochemical areas
- Gas Station
- Railways
- Ship port
- Public Security
- Fire Protection

INCLUDED ACCESSORIES:

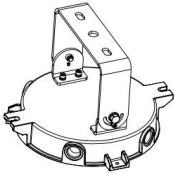

Trunnion mount



Pendant mount



OPTIONAL ACCESSORIES:

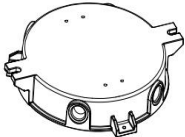

Ceiling mount

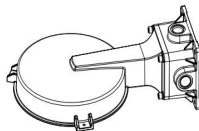

Wall bracket



25° Stanchion mount

HA05-100-U-50-000-CG-T-DM

WATTAGE	CCT	LUMENS	EFFICACY	VOLTAGE	CRI	POWER FACTOR	Surge Protection
100W	5000K	13,500LM	135lm/W	100-277V	70	0.9	10kV line-line, 10kV line-earth

HA05-150-U-50-000-CG-T-DM

WATTAGE	CCT	LUMENS	EFFICACY	VOLTAGE	CRI	POWER FACTOR	Surge Protection
150W	5000K	20,250LM	135lm/W	100-277V	70	0.9	10kV line-line, 10kV line-earth

HA05-240-U-50-000-CG-T-DM

WATTAGE	CCT	LUMENS	EFFICACY	VOLTAGE	CRI	POWER FACTOR	Surge Protection
240W	5000K	32,400LM	135lm/W	100-277V	70	0.9	10kV line-line, 10kV line-earth

MEASUREMENTS

100W

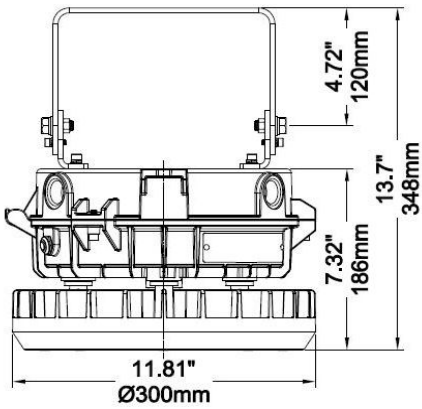

Trunnion mount

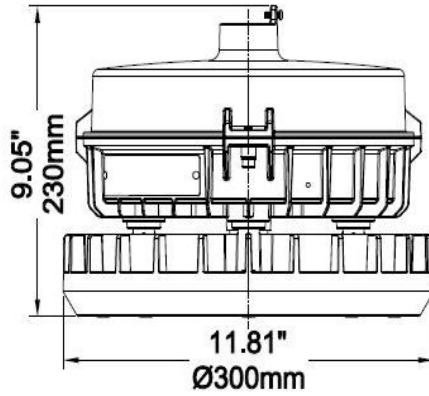

Pendant mount

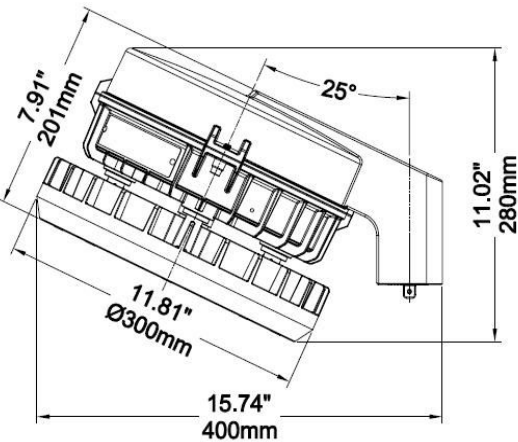

25° Stanchion mount

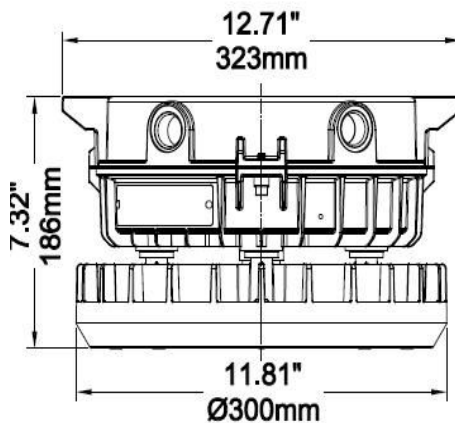

Ceiling mount

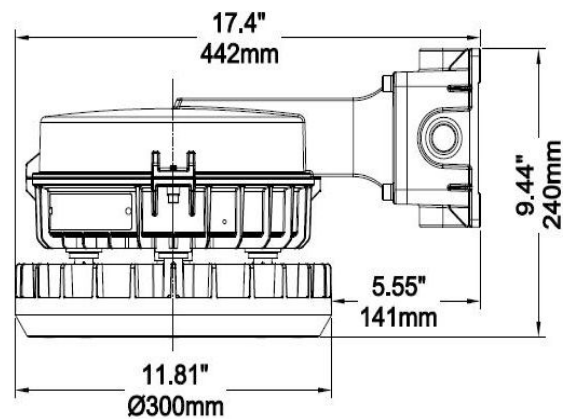

Wall bracket

MEASUREMENTS

150W
240W

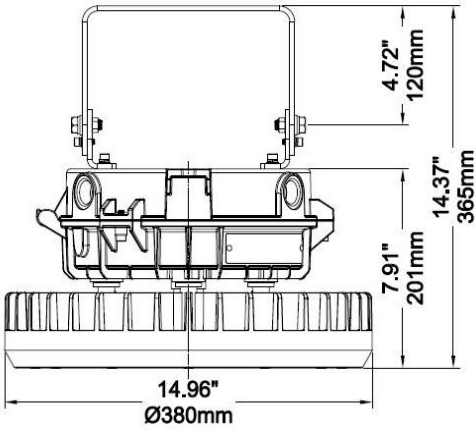

Trunnion mount

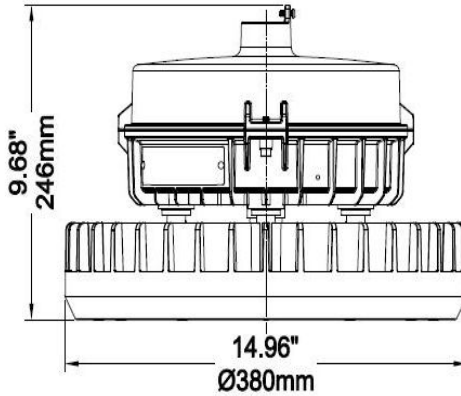

Pendant mount

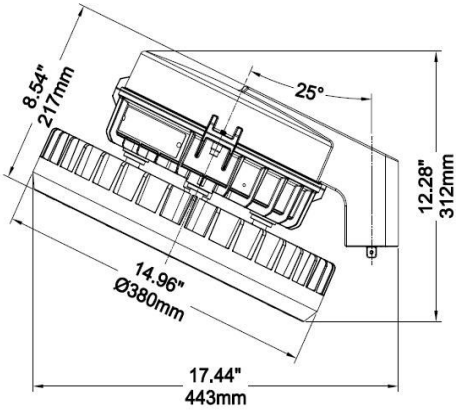

25° Stanchion mount

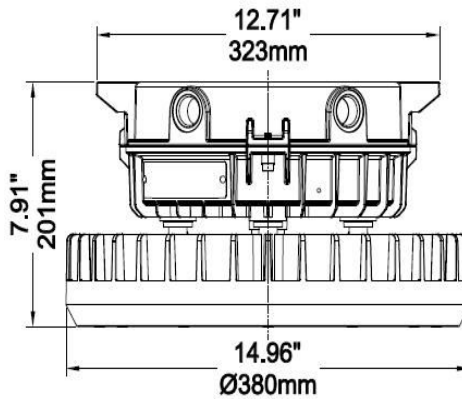

Ceiling mount

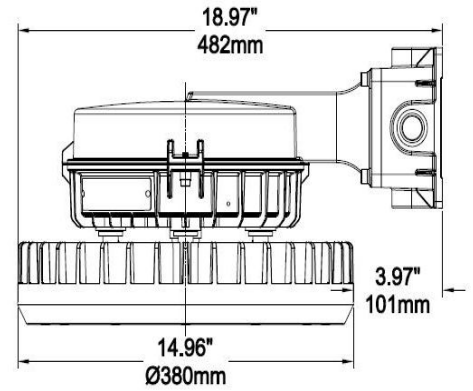

Wall bracket

MODEL	QTY	NET WEIGHT	MASTER CARTON SIZE	GROSS WEIGHT	PCS CTN	UPC CODE
HA05-100-U-50-000-CG-T-DM	1	17.86lbs	14.17"x14.17"x11.81"	21.38lbs	1	
HA05-150-U-50-000-CG-T-DM	1	24.91lbs	18.50"x18.50"x12.60"	31.09lbs	1	
HA05-240-U-50-000-CG-T-DM	1	24.91lbs	18.50"x18.50"x12.60"	31.09lbs	1	